

DIN 18014



ICS 29.120.50; 91.140.50

Supersedes
DIN 18014:2007-09

**Foundation earth electrode –
Planning, execution and documentation,
English translation of DIN 18014:2014-03**

Fundamentenerder –
Planung, Ausführung und Dokumentation,
Englische Übersetzung von DIN 18014:2014-03

Prise de terre de fondation –
Planification, exécution et documentation,
Traduction anglaise de DIN 18014:2014-03

Document comprises 29 pages

Translation by DIN-Sprachendienst.
In case of doubt, the German-language original shall be considered authoritative.



A comma is used as the decimal marker.

Contents

	Page
Foreword	3
1 Scope	4
2 Normative references	4
3 Terms and definitions	5
4 Requirements for foundation earth electrode design	7
4.1 General	7
4.2 Protective equipotential bonding via the main earthing busbar	8
4.3 Functional equipotential bonding	8
4.3.1 EMC requirements	8
4.3.2 Lightning protection systems	8
5 Execution	8
5.1 General	8
5.2 Foundation earth electrode	8
5.3 Ring earth electrode	9
5.4 Earth electrodes in plain concrete or fibre reinforced concrete foundations	9
5.5 Earth electrodes in reinforced concrete foundations	9
5.6 Pad foundations	9
5.7 Foundations with an enhanced earthing contact resistance	9
5.7.1 General	9
5.7.2 Common bonding network (CBN)	10
5.8 Connection components	10
5.9 Connections	11
6 Materials	11
6.1 Foundation earth electrodes and functional bonding conductors	11
6.2 Ring earth electrodes	11
6.3 Materials for connection components and connectors for foundation earth electrodes	12
6.4 Materials for connection components and connectors for ring earth electrodes	12
7 Documentation and resistance measurement	13
7.1 General	13
7.2 Documentation	13
7.3 Resistance measurement	13
Annex A (informative) Documentation form for foundation earth electrodes	26
Annex B (informative) Criteria for designing foundation earth electrodes	28
Bibliography	29

Foreword

This standard has been prepared by Working Committee NA 005-09-85 AA *Elektrische Anlagen in Wohngebäuden* of the *Normenausschuss Bauwesen* (NABau) (Building and Civil Engineering Standards Committee).

Earthing systems for buildings are intended

- to ensure protection against electric shock,
- to enhance the effect of protective equipotential bonding,
- to enhance the effect of functional equipotential bonding,
- to ensure the potential grading within the building,
- to ensure the earthing of lightning protection systems.

Attention is drawn to the possibility that some of the elements of this document may be the subject of patent rights without these having been identified here. DIN [and/or DKE] shall not be held responsible for identifying any or all such patent rights.

Amendments

This standard differs from DIN 18014:2007-09 as follows:

- a) the standard has been restructured;
- b) requirements regarding foundations made from fibre concrete and those with a higher earthing contact resistance have been specified;
- c) where the use of ring earth electrodes is necessary, a functional bonding conductor in the concrete foundation is required;
- d) requirements for the mesh size for meshed functional bonding conductors and regarding the connection to any ring earth electrode have been specified;
- e) details of the documentation and resistance measurement have been specified.

Previous editions

DIN 18014: 1994-02, 2007-09

1 Scope

This standard applies to the design and construction of foundation earth electrodes. The requirement for the installation of such electrodes is set out in DIN VDE 0100-540 (VDE 0100-540), DIN 18015-1, and in the *Technische Anschlussbedingungen für den Anschluss an das Niederspannungsnetz* (TAB) issued by the electricity suppliers.

Foundation/ring earth electrodes as specified here are designed to serve the following purposes:

- earthing of systems involving protective equipotential bonding via the main earthing busbar, as specified in DIN VDE 0100-540 (VDE-0100-540);
- functional equipotential bonding and functional earthing;
- potential grading in buildings, as specified in DIN VDE 0100-444 (VDE 0100-444) and DIN EN 50310 (VDE 0800-2-310);
- earthing of lightning protection and overvoltage protection systems.

The requirements specified for ring earth electrodes are also applicable in cases where such electrodes are to be installed on sites with existing buildings.

2 Normative references

The following documents, in whole or in part, are normatively referenced in this document. For dated references, only the edition cited applies. For undated references, the latest edition of the referenced document (including any amendments) applies.

DIN 1045-2, *Concrete, reinforced and prestressed concrete structures — Part 2: Concrete — Specification, properties, production and conformity — Application rules for DIN EN 206-1*

DIN 18195-9, *Water-proofing of buildings and structures — Part 9: Penetrations, transitions, connections and endings*

DIN 18533, *Water-proofing of below-ground structures*¹⁾

DIN EN 206, *Concrete — Part 1: Specification, performance, production and conformity*

DIN EN 50310 (VDE 0800-2-310), *Application of equipotential bonding and earthing in buildings with information technology equipment*

DIN EN 50522 (VDE 0101-2), *Earthing of power installations exceeding 1 kV a.c.*

DIN EN 61557-4 (VDE 0413-4), *Electrical safety in low voltage distribution systems up to 1000 V a.c. and 1500 V d.c. — Equipment for testing, measuring or monitoring protective measures — Part 4: Resistance of earth connection and equipotential bonding*

DIN EN 61936-1 (VDE 0101-1), *Power installations exceeding 1 kV a.c. — Part 1: Common rules*

DIN EN 62305 (VDE 0185-305) series, *Protection against lightning*

DIN EN 62561-1 (VDE 0185-561-1), *Lightning protection system components (LPSC) — Part 1: Requirements for connection components*

1) In preparation by Technical Committee NA 005-02-13 AA *Abdichtungen für erdberührte Bauteile*.

DIN EN 62561-2 (VDE 0185-561-2), *Lightning protection system components (LPSC) — Part 2: Requirements for conductors and earth electrodes*

DIN EN 62561-5 (VDE 0185-561-5), *Lightning protection system components (LPSC) — Part 5: Requirements for earth electrode inspection housings and earth electrode seals*

DIN EN ISO 17660 (all parts), *Welding — Welding of reinforcing steel*

DIN EN ISO 4063, *Welding and allied processes — Nomenclature of processes and reference numbers*

DIN VDE 0100-200 (VDE 0100-200), *Low-voltage electrical installations — Part 200: Definitions*

DIN VDE 0100-410 (VDE 0100-410), *Low-voltage electrical installations — Part 4-41: Protection for safety — Protection against electric shock*

DIN VDE 0100-444 (VDE 0100-444), *Low-voltage electrical installations — Part 4-444: Protection for safety — Protection against voltage disturbances and electromagnetic disturbances*

DIN VDE 0100-540 (VDE 0100-540), *Low-voltage electrical installations — Part 5-54: Selection and erection of electrical equipment — Earthing arrangements and protective conductors*

DIN VDE 0151 (VDE 0151), *Material and minimum dimensions of earth electrodes with respect to corrosion*

DIN VDE 0618-1 (VDE 0618-1), *Equipment for equipotential bonding — Equipotential bush for main equipotential bonding*

IEC 60050-195, *International Electrotechnical Vocabulary — Part 195: Earthing and protection against electric shock*

Verordnung zum Erlass von Regelungen des Netzanschlusses von Letztverbrauchern in Niederspannung und Niederdruck (German Regulation regarding the issue of regulations on the connection of end users to low voltage or low pressure systems). Artikel I Verordnung über Allgemeine Bedingungen für den Netzanschluss und dessen Nutzung für die Elektrizitätsversorgung in Niederspannung (Niederspannungsanschlussverordnung (NAV) (Article I German Regulation on the general conditions for connection to low voltage supply systems)²⁾*

*Technische Anschlussbedingungen für den Anschluss an das Niederspannungsnetz (Technical conditions for connection to low voltage systems) (TAB 2007)**)*

3 Terms and definitions

For the purposes of this standard, the terms and definitions given in DIN VDE 0100-200 (VDE 0100-200) and the following apply.

3.1

local earth

part of the earth in electrical contact with an earth electrode and the electrical potential of which is not necessarily equal to zero

[SOURCE: IEC 60050-195:1998, 195-01-03, modified]

*) Translator's note: As of 20 June 1980, *BGBI.* (German Federal Law Gazette) I, p. 2477 (no. 50).

2) Registered in the DITR database of *DIN Software GmbH*, obtainable from *Beuth Verlag GmbH*, 10772 Berlin, Germany.

***) Issued by *Bundesverband der Energie- und Wasserwirtschaft e.V.* (BDEW).

3.2

earth electrode

conductive part, which may be embedded in a specific conductive medium (e.g. concrete), in electric contact with the Earth

[SOURCE: IEC 60050-195:1998, 195-02-01, modified]

3.3

earthing contact

electric contact with the Earth

3.4

foundation earth electrode

conductive part embedded in concrete of a building foundation in the form of a closed loop

3.5

ring earth electrode

conductive part embedded in the ground around a building foundation in the form of a closed loop

Note 1 to entry: In DIN VDE 0100-540 (VDE 0100-540) the term *Fundamenterder, in Erde verlegt* is used instead of "Ringerder".

3.6

earthing arrangement

all the electrical connections and devices used in the earthing of a system, an installation and equipment

Note 1 to entry: Electrical connections and devices include earthing conductors, footings of masts or poles, concrete reinforcing bars, metal cable sheaths.

[SOURCE: IEC 60050-195:1998, 195-02-20]

3.7

earthing conductor

conductor which provides a conductive path or part of a conductive path, between a given point in a system, or in an installation or in equipment, and an earth electrode

EXAMPLE Cable connecting main earthing busbar and earthing conductor.

[SOURCE: IEC 60050-195:1998, 195-02-03]

3.8

connection component

conductive component of an earth electrode permitting the latter to be connected to other conductive components

3.9

terminal lug

connection component in the form of strip or wire that permits electrical continuity with other conductive components outside the foundation

3.10

connection plate

conductive component embedded in concrete, used as connection component

Note 1 to entry: The main earthing point may serve as a connection plate.

3.11**functional bonding conductor**

conductor provided for functional equipotential bonding

EXAMPLE Cable providing electrical connection between conductors for equipotential bonding.

[SOURCE: IEC 60050-195:1998, 195-02-16]

3.12**protective bonding conductor**

protective conductor provided for protective equipotential bonding

[SOURCE: IEC 60050-195:1998, IEC 195-02-10]

3.13**main earthing busbar**

terminal or busbar which is part of the earthing arrangement of an installation and enables the electrical connection of a number of conductors for earthing purposes

[SOURCE: IEC 60050-195:1998, IEC 195-02-33, modified]

3.14**perimeter insulation**

thermal insulation fitted around the parts of a structure in contact with the ground

3.15**expansion joint**

joint that permits relative movement between components as caused by expansion, settlement, etc. so as to preclude the occurrence of detrimental mechanical stresses in these components

3.16**connection**

electrical connection between parts of the earth electrode and the functional bonding conductor, and the reinforcing bars by welding, bolting or clamping

4 Requirements for foundation earth electrode design**4.1 General**

The foundation earth electrode is a conductive component embedded in the building foundation, which is in continuity with the earth and, via the main earthing busbar, connected to the electrical installation of the building. Thus, the electrode is part of the electrical installation as set out in the *Niederspannungsanschlussverordnung*.

The foundation earth electrode serves to provide continuity with the earth in order to

- permit protective measures to be taken with regard to the electrical installation,
- conduct any earth fault or protective conductor currents to the earth without this causing undue thermal, thermomechanical or electromechanical stresses or give rise to electric shock, originating from such currents,
- permit any functional requirements to be satisfied.

As defined above, foundation earth electrodes are electrodes embedded in concrete. If, for structural reasons, a concrete foundation is to have an enhanced earthing contact resistance, the electrode is to be installed in the surrounding ground and then termed "ring earth electrode". Criteria for selecting the proper type of electrode are found in Annex B (informative).

4.2 Protective equipotential bonding via the main earthing busbar

A foundation earth electrode improves the effectiveness of the protective equipotential bonding.

It is to be connected to the main earthing busbar.

Where a ring earth electrode is installed outside the foundation, it is necessary to provide an additional functional bonding conductor for potential grading within the foundation.

4.3 Functional equipotential bonding

4.3.1 EMC requirements

A foundation earth electrode in conjunction with an additional functional bonding conductor ensures functional equipotential bonding to comply with EMC requirements.

4.3.2 Lightning protection systems

Where lightning protection systems are to be installed, additional measures as detailed in the DIN EN 62305 series of standards (VDE 0185-305) are to be taken.

5 Execution

5.1 General

Foundation/ring earth electrodes shall be installed as a closed loop. Where larger buildings are involved, the electrodes shall be meshed. The mesh size shall not exceed 20 m × 20 m. Smaller mesh sizes may be required if the electrodes also form part of a lightning protection system (see DIN EN 62305 (VDE 0185-305) series). Where buildings are subject to particular requirements (e.g. buildings in which IT equipment is installed), additional measures (e.g. those detailed in DIN EN 50310 (VDE 0800-2-310)) may have to be taken. For power installations with rated voltages exceeding 1 kV a.c., the specifications of DIN EN 50522 (VDE 0101-2) and DIN EN 61936-1 (VDE 0101-1) shall also be considered.

NOTE 1 Where structures are waterproofed (e.g. basements constructed in watertight concrete or with a bitumen membrane, buildings with perimeter insulation), earthing contact between the electrode and the surrounding ground might be impaired (see 5.7).

With regard to the corrosion protection of earth electrodes, the specifications in DIN VDE 0151 (VDE 0151) are to be observed.

NOTE 2 See Annex B for details regarding the mesh size.

5.2 Foundation earth electrode

The earth electrode shall be installed either in the foundation below the exterior walls or in the foundation slab (see Figures 1, 2 and 3).

It shall be embedded in concrete so as to be covered by the concrete by at least 5 cm on all sides.

Where electrodes in the form of steel strip are to be installed in plain concrete foundations, they should be laid on edge so as to ensure complete embedment. For reinforced concrete foundations with the concrete compacted mechanically (e.g. by using an immersion vibrator), the strip may also be laid flat.

The foundation earth electrode shall not be passed across expansion joints. At joints in concrete walls, the electrode may be passed through connection components to the outer face of the wall. For masonry walls, the electrodes may be passed through the wall via terminal lugs. The connection components shall be connected using flexible copper or aluminium cable straps or earthing conductors of at least 50 mm² cross section. It shall be possible for these points to be checked at any time (see Figure 4).

5.3 Ring earth electrode

A ring earth electrode shall be installed around the perimeter of the foundation, in contact with the ground.

In order to ensure a uniform and low earth resistance throughout, the electrode shall be placed at a distance from the foundation in moist soil at a frost-free depth.

NOTE Special consideration shall be given, for example, in the case of large roof overhangs.

Examples of installation:

- placing the electrode in the working space at the side of the foundation, possibly below any drainage blanket or filter layer (see Figure 5a);
- placing the electrode below the base of the exterior walls (see Figure 5b);
- placing the electrode outside of any frost wall (see Figure 5c).

5.4 Earth electrodes in plain concrete or fibre reinforced concrete foundations

Earth electrodes in plain concrete or fibre reinforced concrete foundations shall be installed as shown in Figure 6, using spacers during concrete placement to hold the electrodes in place (see Figure 7).

Where an embedment of the electrode to a depth of at least 5 cm on all sides cannot be ensured (e.g. due to the placement technique used), a ring earth electrode as in 5.3 is to be installed.

5.5 Earth electrodes in reinforced concrete foundations

Earth electrodes in reinforced concrete foundations shall be installed as shown in Figure 8, providing permanent electrical continuity between the electrode and the reinforcement by connecting both at intervals of not more than 2 m. This shall be done by welding, bolting or clamping (see 5.9).

5.6 Pad foundations

For structures with pad foundations (e.g. for columns), earth electrodes, measuring at least 2,5 m long, shall be provided in each foundation.

All pad foundations shall be interconnected to ensure equipotential bonding between the foundations. Care shall be taken to ensure adequate corrosion protection of the connecting leads.

If, for structural reasons, an earth electrode is to have an enhanced earthing contact resistance (see 5.7), a ring electrode as in 5.3 is to be provided.

5.7 Foundations with an enhanced earthing contact resistance

5.7.1 General

Where there is no adequate contact of a foundation earth electrode with the ground due to the presence of

- water resistant concrete as in DIN EN 206 and DIN 1045-2 (watertight concrete construction) (see Figure 9),
- bitumen tanking (e.g. bitumen sheeting, polymer modified bitumen coating) (see Figure 10),
- impact resistant plastic sheeting,
- thermal insulation (perimeter insulation) on the bottom face or the side faces of the foundation (see Figure 11), or
- additional soil layers (e.g. from recycled material) of poor electrical conductivity and with impaired capillary effect,

a ring earth electrode shall be used.

5.7.2 Common bonding network (CBN)

In order to cope with electromagnetic disturbances, a common bonding network as specified in DIN VDE 0100-444 (VDE 0100-444) shall be provided. In addition, a functional bonding conductor made of wire or strip around the perimeter of a reinforced concrete foundation shall be laid. The conductor shall be meshed to have a mesh size not greater than 20 m × 20 m and shall be permanently connected to the reinforcement at intervals not exceeding 2 m. See 5.2 for further details.

A connection shall be made between the functional bonding conductor and the following:

- the main earthing busbar, for protective equipotential bonding (see DIN VDE 0100-410 (VDE 0100-410));
- the ring earth electrode, along the perimeter of the foundation, at intervals not greater than 20 m;
- the lightning protection system, at each down conductor;
- further conductive components, for functional equipotential bonding.

Other measures, such as those specified in DIN EN 50310 (VDE 0800-2-310) and DIN EN 62305-4 (VDE 0185-305-4) may need to be taken.

5.8 Connection components

Connection components are required for connection of the earthing system with the electrical installation. Such connections include those to

- the main earthing busbar, for protective equipotential bonding,
- any additional equipotential bonding bars,
- the down conductors of a lightning protection system,
- other metallic parts of the installation.

Components for connection to the main earthing busbar according to DIN VDE 0618-1 (VDE 0618-1), for protective equipotential bonding, shall be located near the main distribution box. Other connection components shall be placed as required (e.g. in services control rooms, lift shafts). All such components shall be identified on the layout drawing, together with any necessary dimensions. See Figure 14 for some examples of connection components.

Terminal lugs should have an exposed length from the point of entry of at least 1,5 m. They shall be marked conspicuously during the construction work.

Where a foundation earth electrode is to form part of a lightning protection system, any necessary additional components shall be used to connect the electrode to the down conductors, the number and types of such components conforming to DIN EN 62305-3 (VDE 0185-305-3).

Care shall be taken to ensure that the contact resistance between the connection components and the foundation/ring earth electrode or equipotential bonding bar is as low as possible, i.e. $\leq 0,2 \Omega$.

Connection components penetrating waterproofing membranes shall comply with the specifications of DIN EN 62561-5 (VDE 0185-561-5) and those of DIN 18195-9³⁾.

3) To be superseded by DIN 18533, which is in preparation.

5.9 Connections

The components of a foundation earth electrode shall be durably connected by welding, bolting or clamping, so as to provide continuity. Welded connections with the reinforcement shall be made in accordance with DIN EN ISO 17660 in conjunction with DIN EN ISO 4063. Welded connections are only permitted following consultation of the responsible specialist engineer. In the case of welded joints, the welded length shall be at least 50 mm.

Where a foundation/ring earth electrode is to form part of a lightning protection system, any connection components used shall conform to DIN EN 62561-1 (VDE 0185-561-1).

If the concrete is compacted mechanically (e.g. by using an immersion vibrator), wedge connectors shall not be used for clamping.

6 Materials

6.1 Foundation earth electrodes and functional bonding conductors

Foundation earth electrodes and functional bonding conductors shall be of

- circular cross section, at least 10 mm in diameter (bars) or
- rectangular cross section, i.e. strip at least 30 mm × 3,5 mm in size.

The electrode may be of bright or galvanized steel.

Where other than normal requirements are to be satisfied, copper or stainless steel may be used. The risk of electrolytic corrosion shall be considered where dissimilar materials are in contact (particularly in cases of contact between earth electrode and structural steel).

In buildings where a transformer power unit is installed, the special requirements according to DIN EN 50522 (VDE 0101-2) and DIN EN 61936-1 (VDE 0101-1) are to be observed.

If a foundation earth electrode is to form part of a lightning protection system, materials for lines shall conform to DIN EN 62561-2 (VDE 0185-561-2).

6.2 Ring earth electrodes

Ring earth electrodes shall have the form of

- round steel bars, at least 10 mm in diameter,
- steel strip, at least 30 mm × 3,5 mm in size, or
- multi-strand copper cables (plain or tinned), with a minimum cross-sectional size of 50 mm².

Bars and strip shall be permanently corrosion resistant (such as stainless steel with > 16 % chromium, > 5 % nickel, > 2 % molybdenum, and < 0,08 % carbon (e.g. material number 1.4571). Hot-dip galvanized material shall not be used.

In buildings where a transformer power unit is installed, the special requirements according to DIN EN 50522 (VDE 0101-2) and DIN EN 61936-1 (VDE 0101-1) are to be observed.

If a ring earth electrode is to form part of a lightning protection system, materials for lines shall conform to DIN EN 62561-2 (VDE 0185-561-2).

6.3 Materials for connection components and connectors for foundation earth electrodes

Terminal lugs and connection plates for foundation earth electrodes shall be made from permanently corrosion resistant material.

Terminal lugs shall be made of

- round steel bars, at least 10 mm in diameter,
- steel strip, at least 30 mm × 3,5 mm in size,
- NYY type copper cables, with a minimum cross-sectional size of 50 mm², or
- multi-strand copper cables (plain or tinned), with a minimum cross-sectional size of 50 mm².

Bars and strip shall be permanently corrosion resistant (such as stainless steel with a content of > 16 % chromium, > 5 % nickel, > 2 % molybdenum, and < 0,08 % carbon (e.g. material number 1.4571). Hot-dip galvanized material shall not be used.

Main earthing points including metal components with nut thread M10 × 1,5 or greater may serve as a connection plate.

Steel connectors embedded in concrete to a depth of at least 5 cm on all sides can be galvanized or ungalvanized.

If a foundation earth electrode is to form part of a lightning protection system, the connectors shall conform to DIN EN 62561-1 (VDE 0185-561-1).

6.4 Materials for connection components and connectors for ring earth electrodes

Connection components and connectors for ring earth electrodes shall have the form of

- round steel bars, at least 10 mm in diameter,
- steel strip, at least 30 mm × 3,5 mm in size, or
- multi-strand copper cables (bare or tinned), with a minimum cross-sectional size of 50 mm².

Round steel bars and strip shall be permanently corrosion resistant (such as stainless steel with a content of > 16 % chromium, > 5 % nickel, > 2 % molybdenum, and < 0,08 % carbon (e.g. material number 1.4571), or shall be made of hot-dip galvanized steel provided with a durable plastic coating. Uncoated hot-dip galvanized material shall not be used.

Buried connections shall be protected using corrosion protection tape at the connection points.

If a ring earth electrode is to form part of a lightning protection system, the connectors shall conform to DIN EN 62561-1 (VDE 0185-561-1).

7 Documentation and resistance measurement

7.1 General

Prior to concrete placement documentation shall be drawn up (see 7.2) and the volume resistance measured by an electrician or a specialist lightning protection systems contractor (see 7.3).

7.2 Documentation

The documentation shall comprise the following:

- layout drawings of earth electrode to be installed, including that of the functional bonding conductor;
- meaningful photos of the earthing systems;
- easily identifiable pictures of connections (e.g. at main earthing busbar, lightning protection system connection components);
- results of resistance measurement as in 7.3.

See Annex A (informative) for an example of such a documentation.

7.3 Resistance measurement

The resistance measurement between the connection component at the main earthing busbar and all other connection components, using the instruments detailed in DIN EN 61557-4 (VDE 0413-4), shall not exceed $0,2 \Omega$ (see 5.8). Measurement shall be made prior to concrete placement.

NOTE In accordance with DIN EN 61557-4 (VDE 0413-4), the current for the smallest measuring range will be 0,2 A.

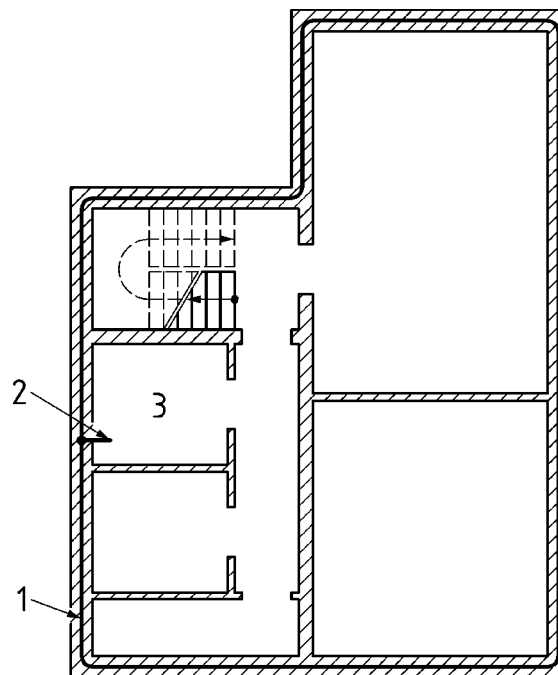

Key

- 1 Foundation earth electrode
- 2 Connection component (terminal lug or connection plate)
- 3 Site of main distribution box

Figure 1 — Siting of foundation earth electrode in detached building (example)

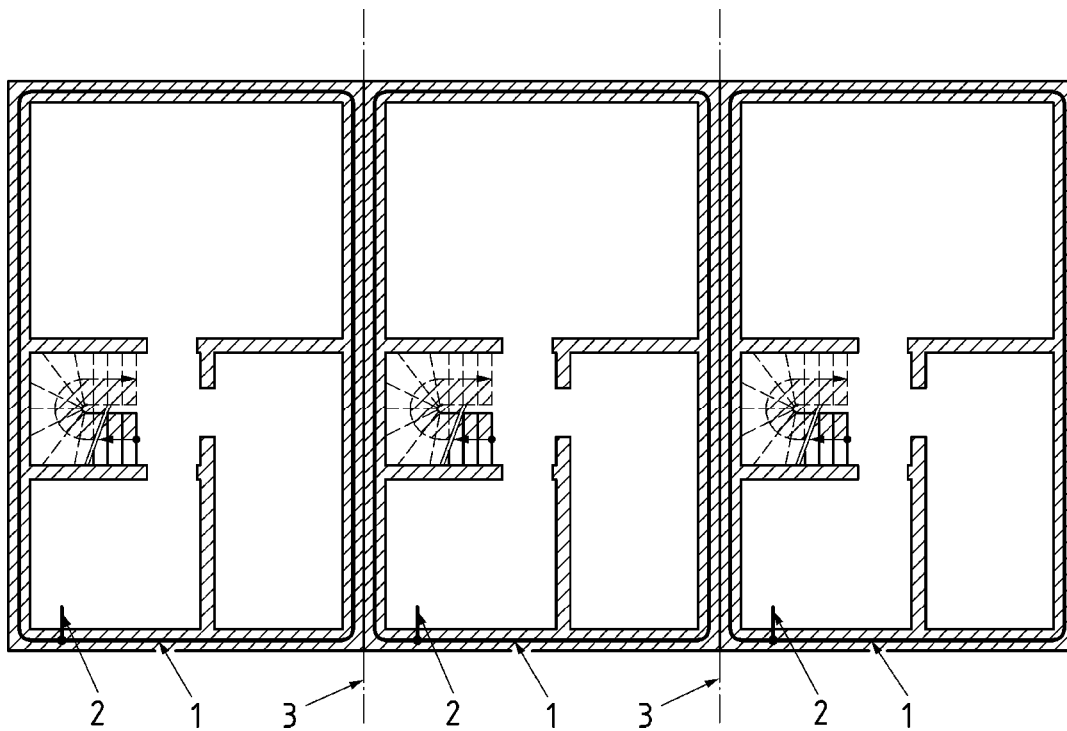

Key

- 1 Foundation earth electrode
- 2 Connection component (terminal lug or connection plate)
- 3 Property boundary

Figure 2 — Siting of foundation earth electrode in terraced houses (example)

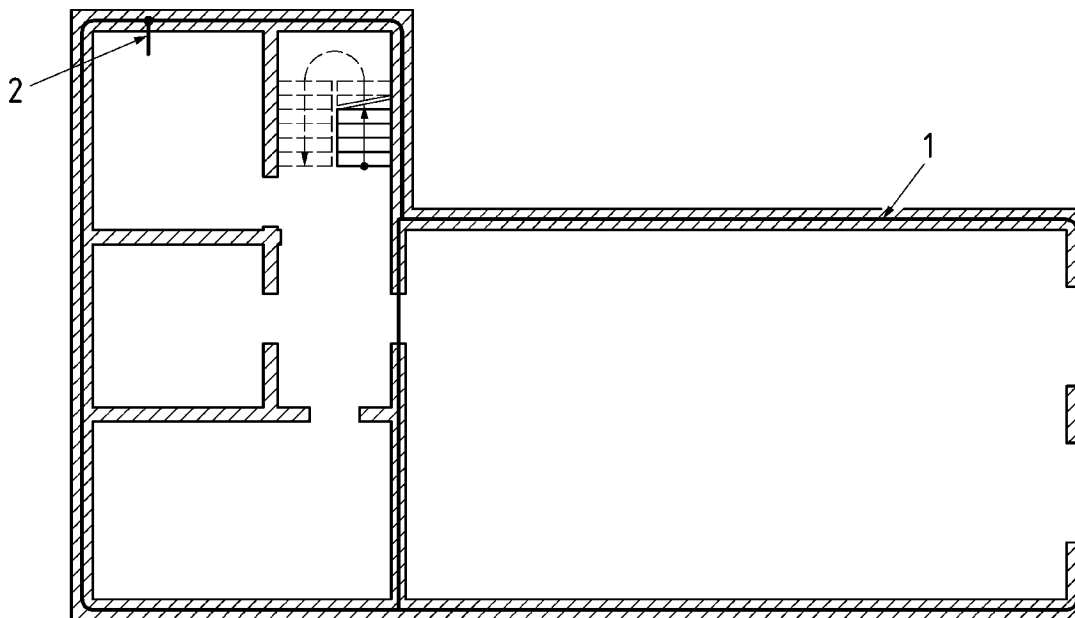

Key

- 1 Foundation earth electrode (mesh size 20 m × 20 m maximum)
- 2 Connection component (terminal lug or connection plate)

Figure 3 — Siting of foundation earth electrode in a larger building (example)

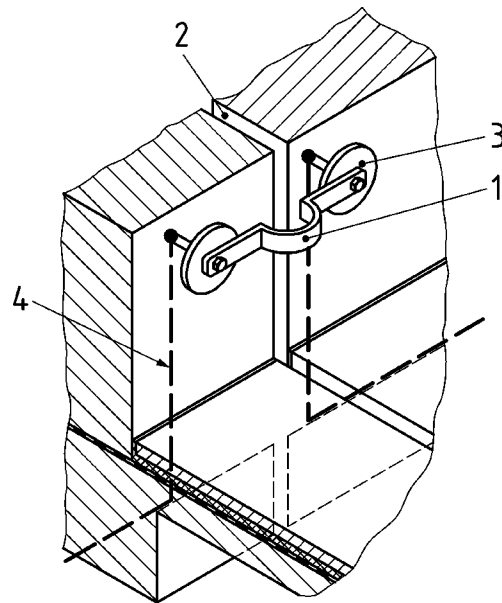
**Key**

- 1 Cu or Al earth strap, 50 mm²
- 2 Expansion joint
- 3 Connection plate/main earthing point
- 4 10 mm steel bar or 30 mm × 3,5 mm strip

Figure 4 — Bridging of expansion joint inside the building using a connection plate (main earthing point) and flexible cables (example)

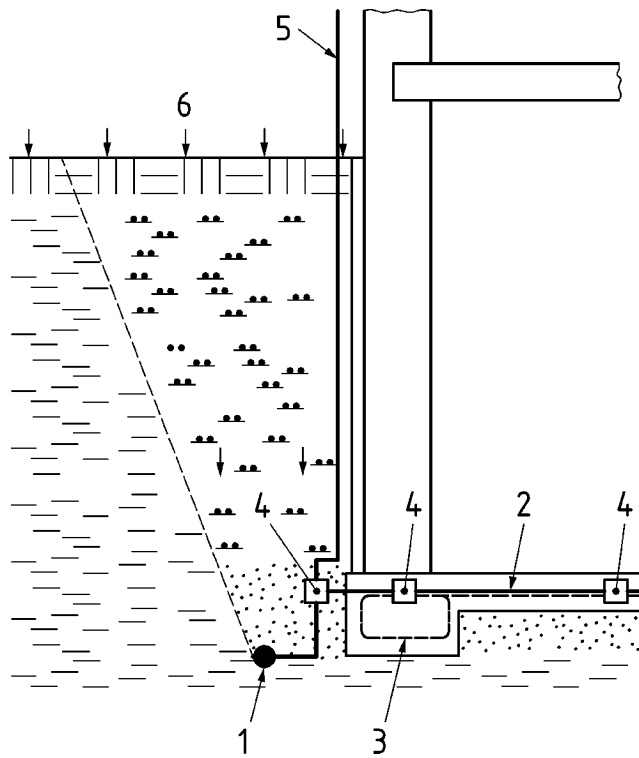

Key

- 1 Ring earth electrode, in contact with the ground
- 2 Functional bonding conductor, connected to reinforcement at intervals not greater than 2 m
- 3 Reinforcement
- 4 Clamp
- 5 Connection component for lightning protection system
- 6 Direction of precipitation

a) Position of ring earth electrode in working space (located below any drainage blanket or filter layer)

Figure 5 — Siting of ring earth electrode (example 1 of 3)

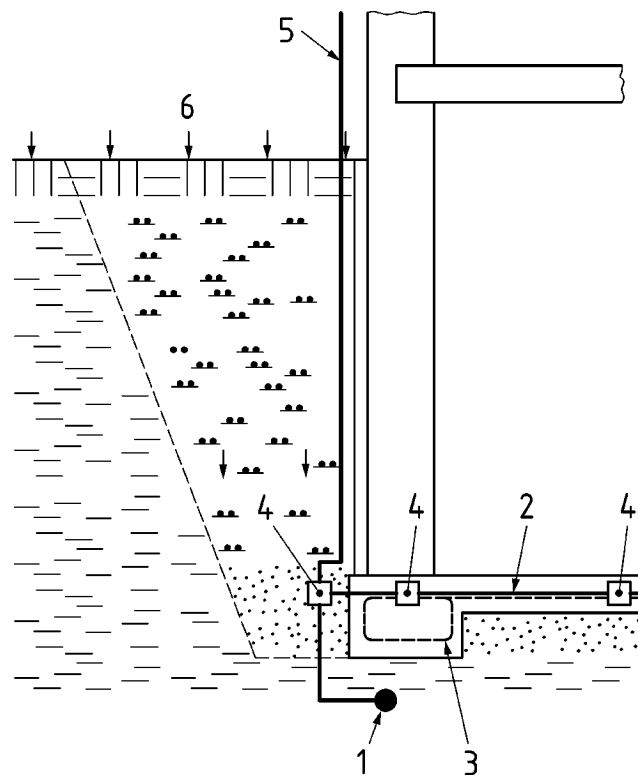
**Key**

- 1 Ring earth electrode, in contact with the ground
- 2 Functional bonding conductor, connected to reinforcement at intervals not greater than 2 m
- 3 Reinforcement
- 4 Clamp
- 5 Connection component for lightning protection system
- 6 Direction of precipitation

b) Position of ring earth electrode below foundation of exterior wall**Figure 5 — Siting of ring earth electrode (example 2 of 3)**

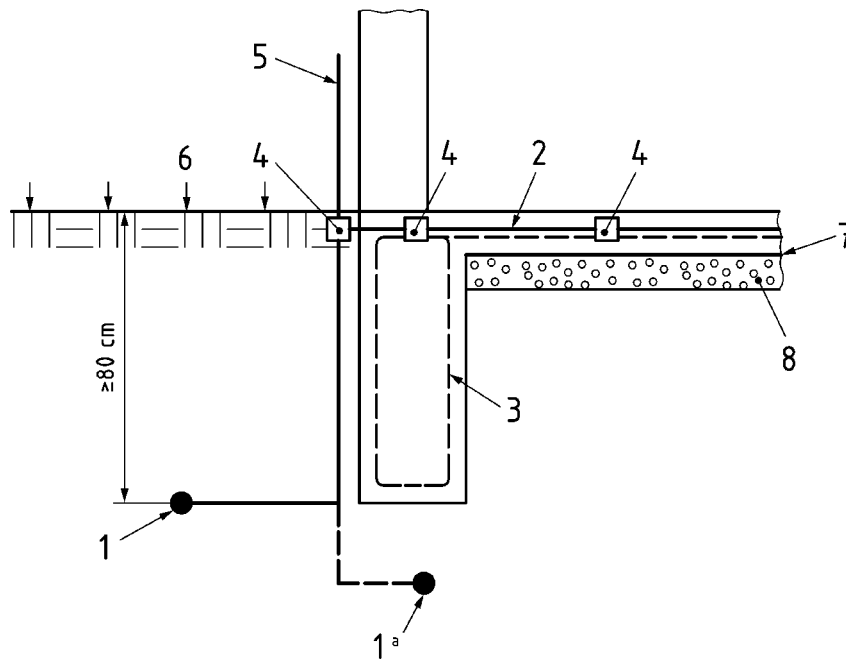

Key

- 1 Ring earth electrode, in contact with the ground
- 1a Alternative position of electrode
- 2 Functional bonding conductor, connected to reinforcement at intervals not greater than 2 m
- 3 Reinforcement
- 4 Clamp
- 5 Connection component for lightning protection system
- 6 Direction of precipitation
- 7 PE membrane
- 8 (Gravel pack) blinding layer

c) Position of ring earth electrode for foundation with water resistant concrete frost wall

Figure 5 — Siting of ring earth electrode (example 3 of 3)

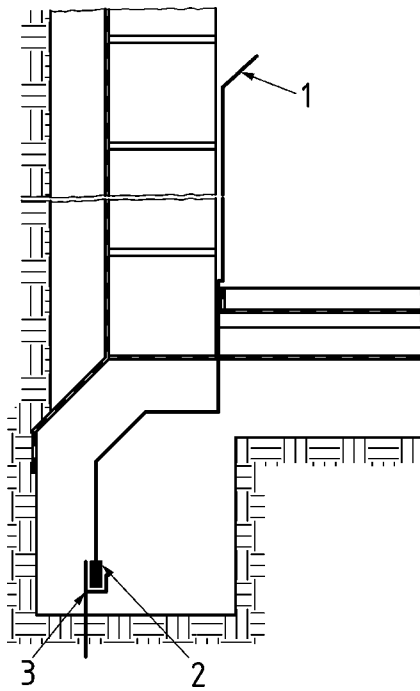

Key

- 1 Terminal lug
- 2 Foundation earth electrode, with concrete cover of 5 cm min.
- 3 Spacer

Figure 6 — Siting of foundation earth electrode in plain concrete foundation (example)

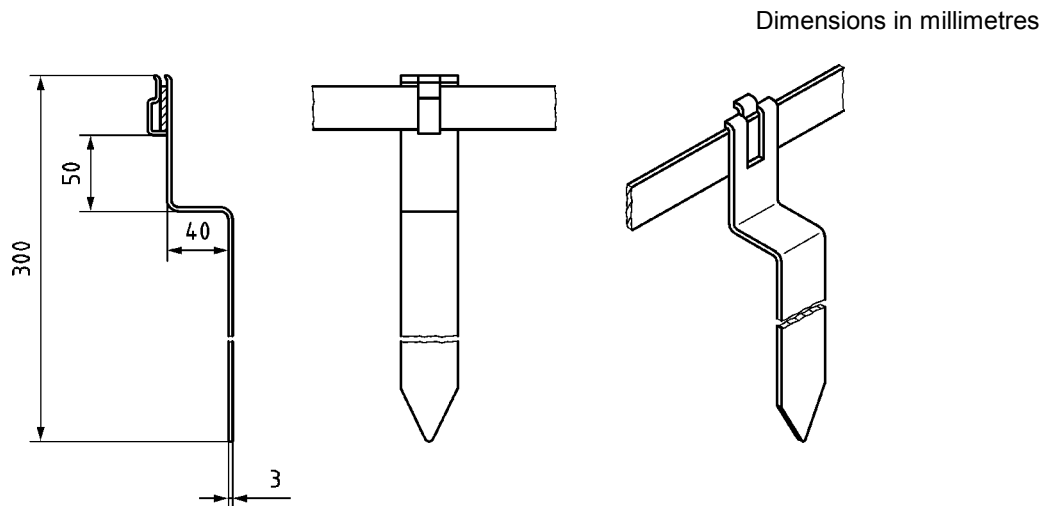
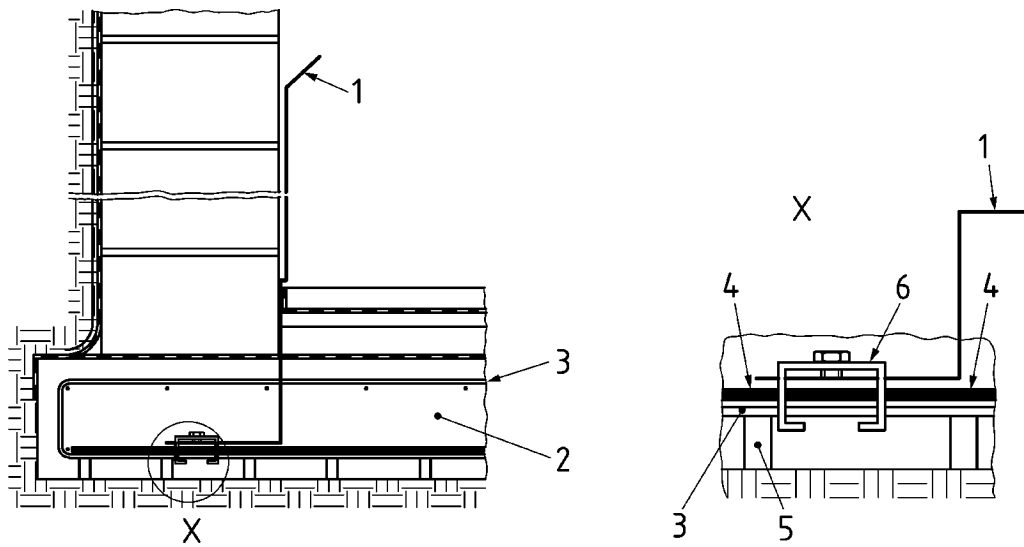

Figure 7 — Spacer for foundation earth electrode (example)



Key

- 1 Terminal lug
- 2 Foundation slab
- 3 Reinforcement
- 4 Foundation earth electrode, connected to reinforcement at 2 m intervals by welding or clamping
- 5 Spacer for reinforcement
- 6 Clamp

Figure 8 — Siting of foundation earth electrode in reinforced concrete foundation (example)

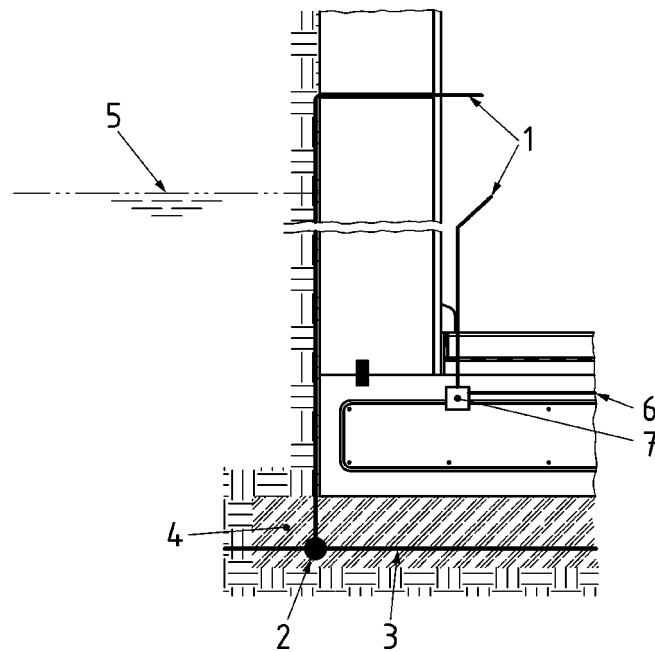
**Key**

- 1 Terminal lug
- 2 Connection to ring earth electrode
- 3 Ring earth electrode
- 4 Blinding layer
- 5 Design water table
- 6 Functional bonding conductor, connected to reinforcement at intervals of 2 m max.
- 7 Connection to reinforcement

Figure 9 — Siting of ring earth electrode below watertight concrete below-ground construction resting on reinforced concrete foundation (example)

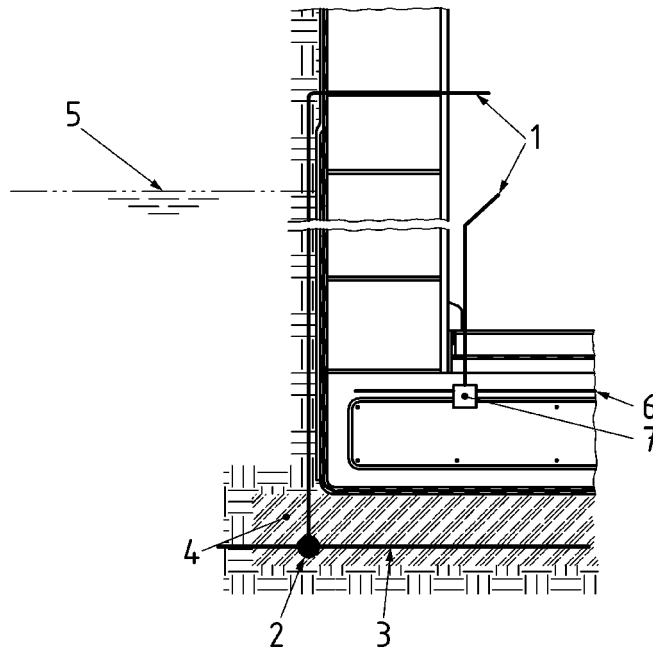

Key

- 1 Terminal lug
- 2 Connection to ring earth electrode
- 3 Ring earth electrode
- 4 Blinding layer
- 5 Design water table
- 6 Functional bonding conductor, connected to reinforcement at intervals of 2 m max.
- 7 Connection to reinforcement

Figure 10 — Siting of ring earth electrode below bitumen membrane resting on reinforced concrete foundation (example)

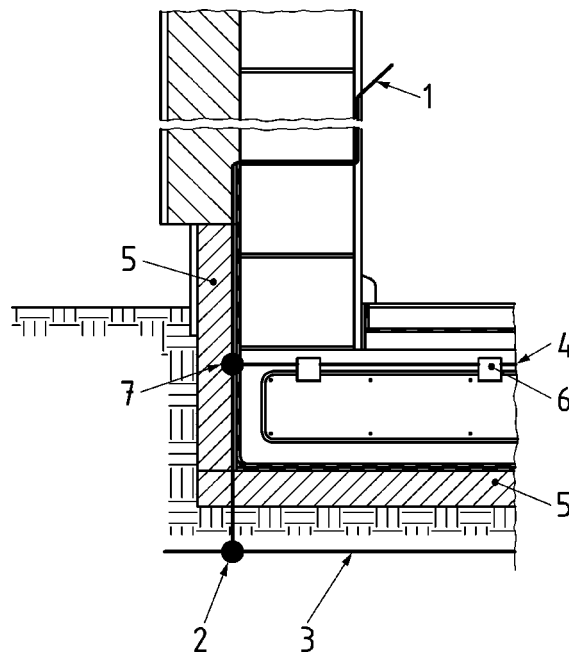
**Key**

- 1 Terminal lug
- 2 Connection to ring earth electrode
- 3 Ring earth electrode
- 4 Functional bonding conductor, connected to reinforcement at intervals of 2 m max.
- 5 Thermal (perimeter) insulation
- 6 Connection to reinforcement
- 7 Connection between ring earth electrode and equipotential bonding bar

Figure 11 — Siting of ring earth electrode, with thermal insulation (perimeter insulation) applied to the side and under the foundation slab in a reinforced concrete foundation (example)

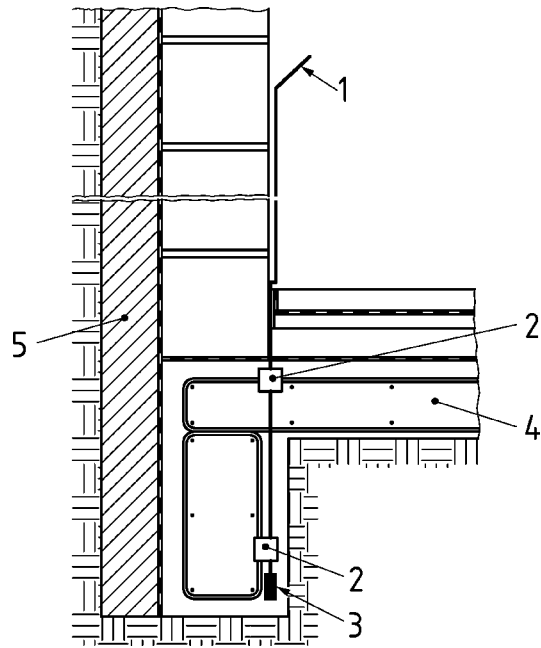

Key

- 1 Terminal lug
- 2 Connection to reinforcement
- 3 Foundation earth electrode
- 4 Reinforced concrete slab
- 5 Thermal insulation (perimeter insulation)

Figure 12 — Siting of ring earth electrode in reinforced concrete foundation with thermal insulation (perimeter insulation) applied at one side only (example)

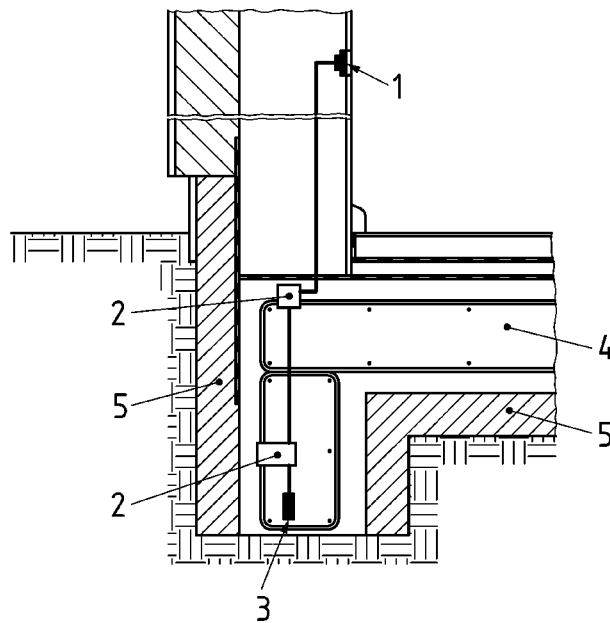

Key

- 1 Connection plate/main earthing point
- 2 Connection to reinforcement
- 3 Foundation earth electrode
- 4 Reinforced concrete slab
- 5 Thermal insulation (perimeter insulation)

Figure 13 — Siting of ring earth electrode in reinforced concrete foundation with thermal insulation (perimeter insulation) applied at two sides (example)

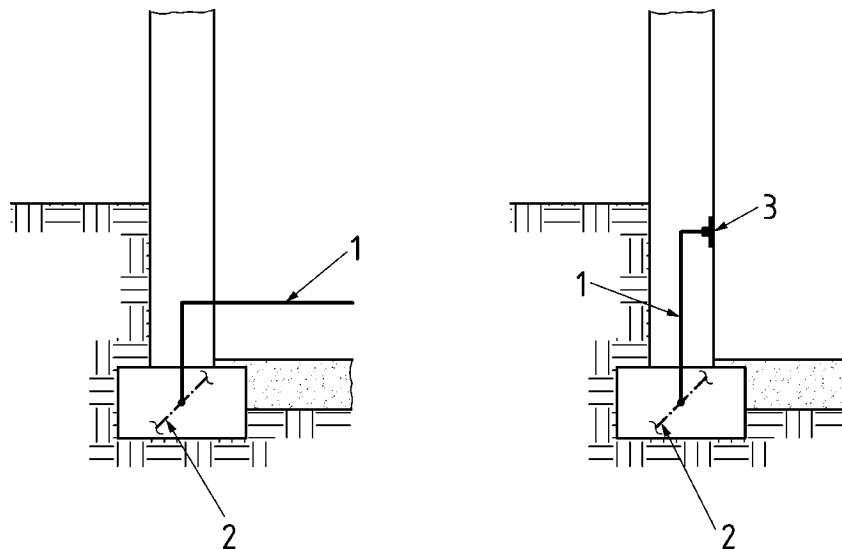

Key

- 1 Terminal lug
- 2 Foundation earth electrode
- 3 Connection plate/main earthing point

Figure 14 — Connection components (terminal lug or connection plate/main earthing point), with internal connection

Annex A (informative)

Documentation form for foundation earth electrodes

This form may be duplicated for further use without prejudice to the copyright held by DIN on the document as a whole.

Documentation for foundation earth electrodes as in DIN 18014 (page 1)

Report no.	Inspection made on:	Person responsible for report:	
Building	Site address:		
	Town (with postal code):		
	Purpose of building:		
	Type of building:		
	Type of foundation:		
Designer	Name:		
	Address:		
	Town (with postal code):		
Contractor	<input type="checkbox"/> Electrician	<input type="checkbox"/> Lightning protection contractor	<input type="checkbox"/> Building contractor supervised by an electrician or specialist lightning protection systems contractor
	Name and company:		
	Address:		
	Town (with postal code):		
Objective of earthing work	<input type="checkbox"/> Protective earthing		
	<input type="checkbox"/> Functional earthing		
Earth electrode design	<input type="checkbox"/> Foundation earth electrode	<input type="checkbox"/> Steel, bright	<input type="checkbox"/> Steel, galvanized
	<input type="checkbox"/> Ring earth electrode	<input type="checkbox"/> Stainless steel	<input type="checkbox"/> Copper
	<input type="checkbox"/> Bars	<input type="checkbox"/> Strip	<input type="checkbox"/>
	Inner connection components	<input type="checkbox"/> Plastic coated galvanized steel <input type="checkbox"/> Stainless steel <input type="checkbox"/> Connection plate/main earthing point <input type="checkbox"/> Copper cable <input type="checkbox"/> Copper cable, NYY type	
	Outer connection components	<input type="checkbox"/> Plastic coated galvanized steel <input type="checkbox"/> Stainless steel, mat. no.: <input type="checkbox"/> Connection plate/main earthing point <input type="checkbox"/> Copper cable	

Documentation for foundation earth electrodes as in DIN 18014 (page 2)

Report no.		
Purpose of report	<input type="checkbox"/> Acceptance/Commissioning	
Results	The construction complies with the design documents	<input type="checkbox"/> Yes <input type="checkbox"/> No
	In all resistance measurements, the values did not exceed 0,2 Ω (as in 5.8)	<input type="checkbox"/> Yes <input type="checkbox"/> No
	Deficiencies:	<input type="checkbox"/> Remedying of defects required
		<input type="checkbox"/> Renewed inspection required
Description, drawings, illustrations of earthing system	<input type="checkbox"/> Drawing no.	<input type="checkbox"/>
	<input type="checkbox"/> Figure no.	<input type="checkbox"/>
This report includes these pages and the following attachments (e.g. drawings, photos): (where the documentation includes a large number of attachments and deals with an extensive range of materials, additional reports may have to be drawn up).		
Place	Date	Stamp and signature of electrician or lightning protection system contractor

Annex B
(informative)

Criteria for designing foundation earth electrodes

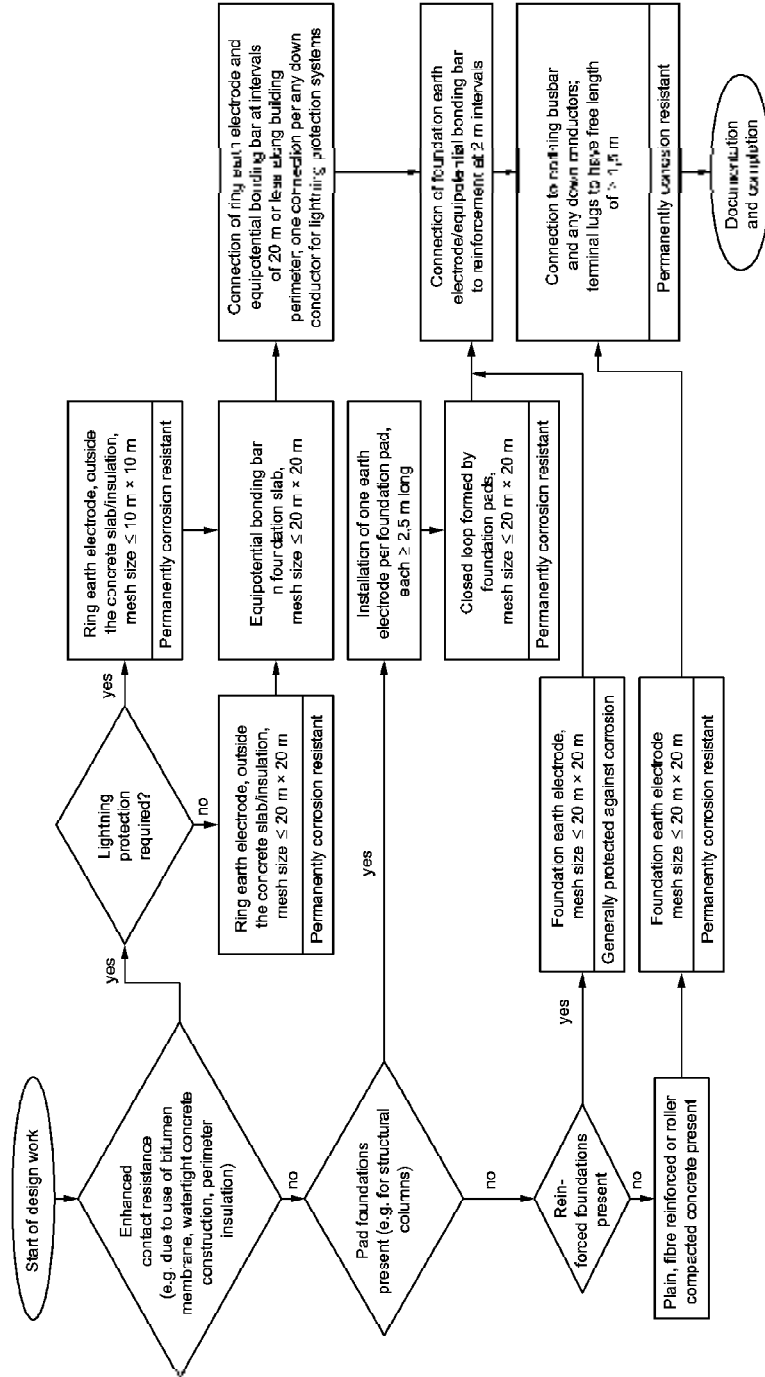

Figure B.1 — Criteria for designing foundation earth electrodes

Bibliography

DAfStb-Richtlinie (DAfStb Code of practice) *Wasserundurchlässige Bauwerke aus Beton* (Waterproof concrete structures)